

CARTRIDGE FILTER ATEX C-327

DESCRIPTION

The cartridge filter model C-327 made out of modular cartridges, ATEX version 21-22, is properly designed to filter dust with danger of explosion classes ST1-ST2. It is equipped with automatic cleaning by means of compressed air.

Operating Principle

The dust-filled air enters the bottom side of the hopper through the inlet connected to the panel. Coarser dust present into the extracted air is immediately depressed by means of the separation chamber and drops into the container hopper because of the lessening of speed. Passing through the quiet chamber dust then enters the filtering cartridges going from the outside into the inside, thereby depositing the impurities in the container hopper. While in function, the filter is always kept at maximum efficiency through a system of cyclical cleaning moving into the opposite direction. A compressed blast of air, gathered in the correct tank, is rapidly injected into the inside of the filtering cartridges, creating a shockingly violent wave in the opposite direction. This

process enables it to release the dust particles and let them far from being deposited on the outside of the filtering cartridges.

Construction Details

The filter is made entirely of a very thick galvanized steel, developed to be very durable over time.

The filter is equipped with a cyclical programme to wash the filtering cartridges. Furthermore, it is comprised of supporting legs, inspection doors, anti-explosion doors, dust container with quick release.

OPTIONALS

High temperature cartridges, fire protection system, spark detector, venturi aluminum tube, quiet chamber, rotative valve and discharge screw, safety railing and ladder.

APPLICATION FIELDS

Engineering, wood, aeronautic, ceramic, food, painting, foundries, chemical, rubber, sugar, cement.

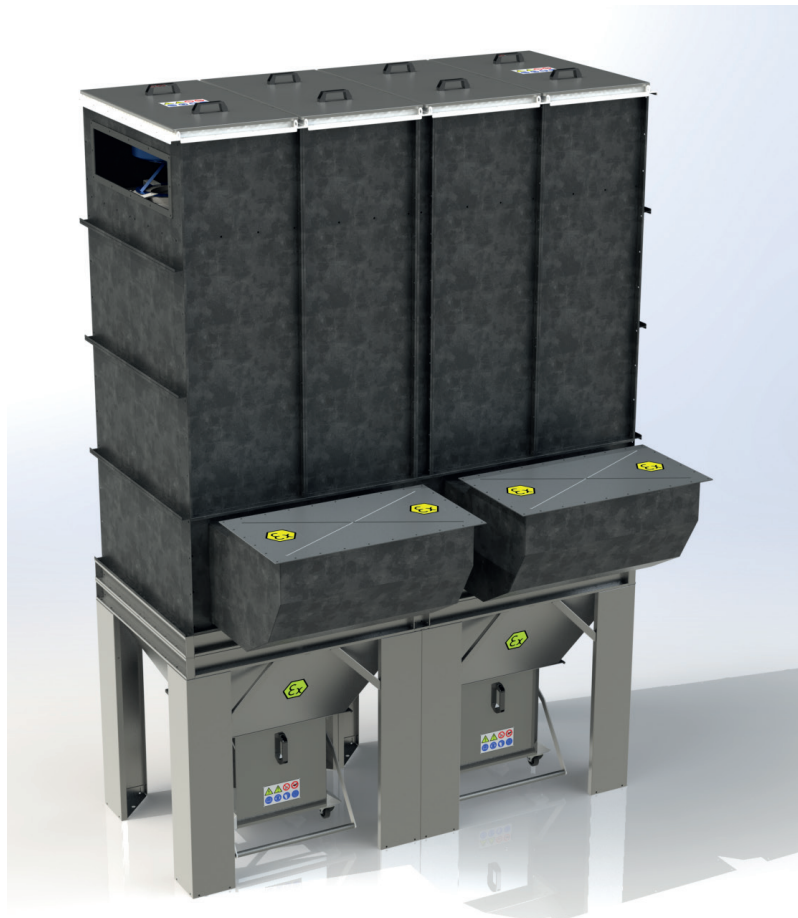

MOD. C327		UNITS	C327-4	C327-6	C327-8	C327-10	C327-12
Filtering surface	m ²		80	120	160	200	240
Quantity of filtering cartridges	n°		4	6	8	10	12
Maxium fume temperature	°C		60				
Types of dust filtered	/		Industrial dusts and fumes				
Cartridge material	/		PES, 275 gr/m2				
Cartridge dimension	mm		Ø 327 x H 1200				
Electrovalves	n°		1	1	1	1	1
Electric Sequencer	n° uscite		1	1	1	1	1
Air tank capacity	n°/l		4x7	6x7	8x7	10x7	12x7
Air tank pressure	Bar		5				
Air compression consumption per pulse	l		7	21	35	63	78
Dust container / capacity	n°/l		1/50	2/50	2/50	3/50	3/50
Antiexplosion doors	n°		1	2	2	3	3
Maximum drop loss	mmH2O		160				
Structure	Material		Painted carbon stainless steel				
Weight	kg		489	620	750	870	1025
A	mm		3440				
B	mm		1237	1782	2327	2827	3372
C	mm		1052				
D	mm		695				

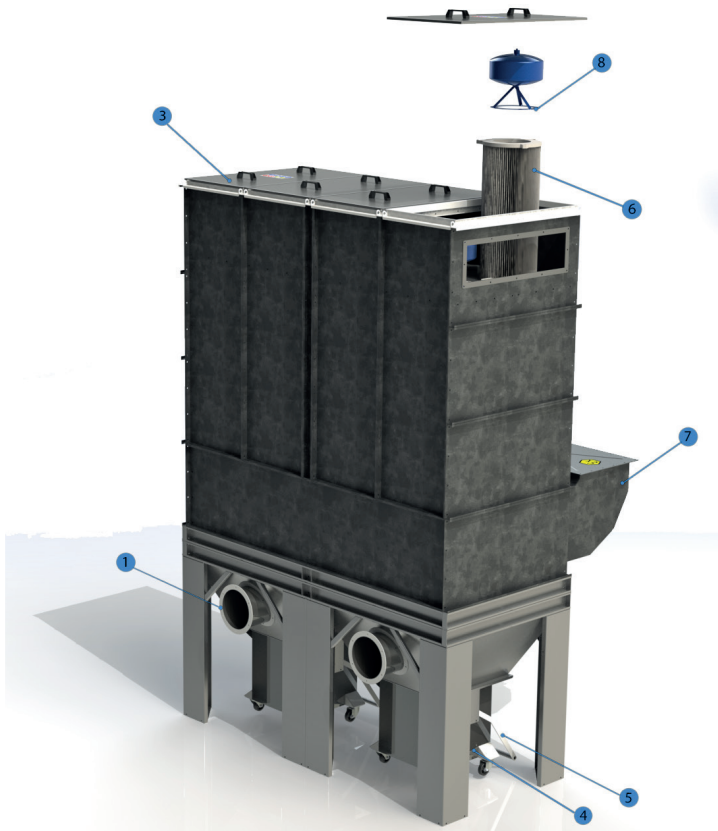
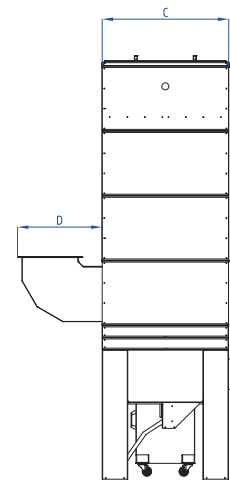
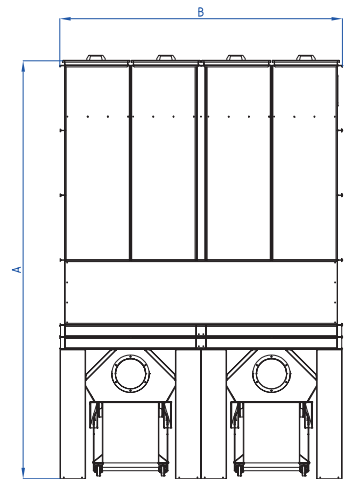

SPARK SEPARATOR

- 1 Air filter inlet
- 2 Outlet panel
- 3 Inspection door
- 4 Dust container
- 5 Quick release handle
- 6 Filtering cartridge
- 7 Outlet panel pan
- 8 Filter cleaning tank